

ULTIMA VECTOR

Semi-concealed system on exposed 24mm grid

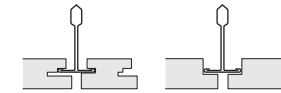

This Technical Data Sheet is offered as an aid to the specification of our products and provides information on our Ultima Vector tiles.

Material	Wet-formed mineral fibre tile, back coated, perforated, acoustically transparent surface membrane.
Finish	Lightly textured, unperforated, non-directional surface. Factory applied treatment for durability, impact, scratch, soil and humidity resistance. Bioblock paint on face and rear inhibits or retards the growth of mould and mildew. Durable edge treatment. Factory applied acrylic latex paint.
Colour	White
Light Reflectance	88% Measured in accordance with ASTM 1477-98.

Item No.	Surface	Edge Detail	Size (mm)
BP 1920 M	Ultima	Vector	600 x 600 x 19

General

Ultima Vector tiles are designed to install on a conventional 24mm exposed tee grid. All full tiles can be removed and reinstalled from below without encroaching into the plenum area. Ultima Vector has a 3mm bevel at 30°. Installed tiles conceal the tee flanges and create a continuous 6mm shadow reveal. Ultima Vector tiles install with a minimum plenum clearance; lighting fixtures and air handling systems will determine the minimum plenum height for the installation.

For best results it is recommended to install Ultima Vector on Armstrong Trulok Prelude 24 XL/TL grid.

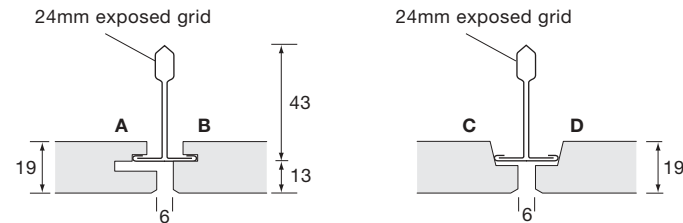

ULTIMA VECTOR

Tile Edges

Ultima Vector tiles feature unique edge detailing. The following section is intended to define and explain the function of the edge details.

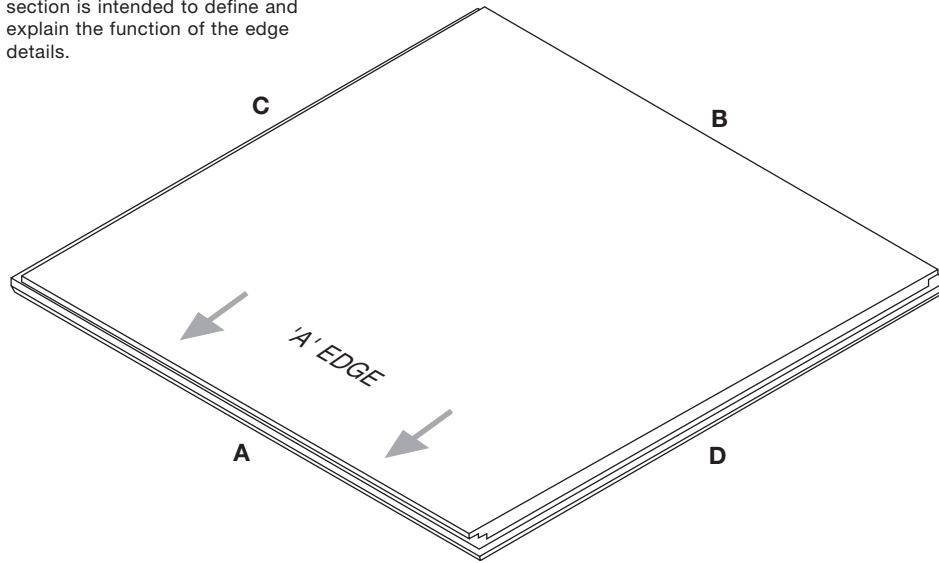

Access Kerf A

The tile edge designated as "A" has a stepped groove detail and is called the access kerf. This edge is the first to engage the suspension system. An arrow printed on the back of the panel will identify this edge.

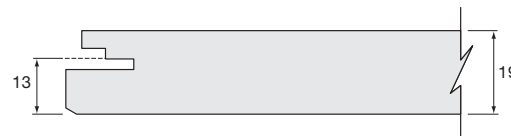

Registration Kerf B

Edge "B" has a single kerf detail that supports the second side and centres the tile in the A - B direction. This edge is referred to as the registration kerf and is opposite edge "A".

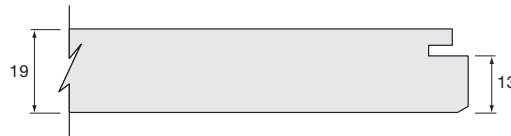

Reverse Tegular Edges C and D

The two remaining tile edges are rebated to fit between the flanges of the grid system. These edges centre the tile in the C - D direction and are called reverse tegular edges.

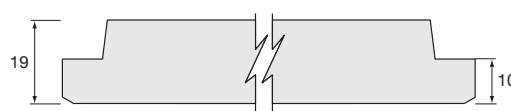

All measurements are in millimetres.

Accessories

①		BP A1796	Border wedge
②		BP A440	Vector border clip
③		BP CA5733 A	Spacer bar
④		BP 5790 M	Vector fixture trim
⑤		BP T2413 H	Shadowline perimeter trim
⑥		BP T1924 HD	Perimeter trim

Perimeter Solutions

Many options are available for perimeter detailing. Regardless of the actual material used, either the grid will rest on the perimeter trim or the face of the tile will. Follow the instructions appropriate for the job conditions.

Grid resting on trim

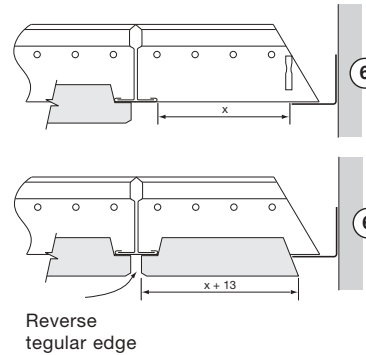
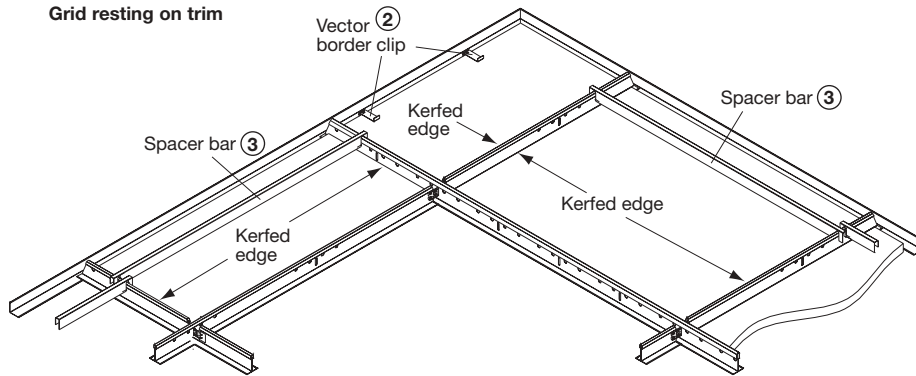

Grid resting on trim :

When this detail is used with Ultima Vector the border tiles are cut to butt against the trim as shown. The cut is made parallel to either the C or D edge of the tile. This will retain the A and B details on opposite sides of the border tile. Ultima is non-directional. Tiles may be rotated at the walls to retain the kerfed edges.

Measuring the tile

Measure the size of the opening from the edge of the T-bar to the edge of the trim and add 13mm. Measure and mark the face side of the tile at both edges.

Cutting and installing the tile

Cut from the face side using a sharp cutter and a straight edge. Angle the cut so that the face side of the tile is about 2mm longer than the back side. This back cut will wedge the panel into the opening and prevent it from shifting away from the trim. Install in the same way as a full sized tile.

Corner tile installation

Preparation of the corner tile will require the removal of two edges. Mark and cut the tile to retain a portion of the B edge. Support the A side of the tile by inserting two Vector Border Clips (BP A440 (2)) to rest on the perimeter trim.

Tile resting on trim

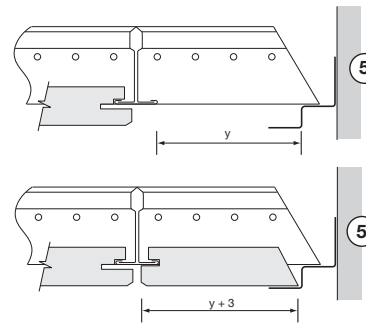
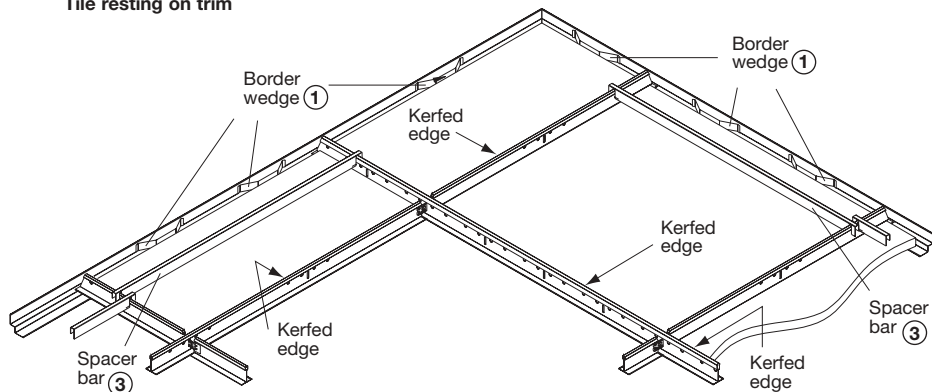

Tile resting on trim :

Another option is to have the grid system raised above the trim by 13mm. This clearance will allow the face of the tile to rest upon the support leg of the trim.

In this installation, the shadowline trim (BP T2413 H (5)) has a 13x13mm offset. The grid is resting up on the upper flange and the face of the tile is on the lower flange. This method will create "small gaps" where the grid passes over the perimeter trim flange, but it eliminates field cut tile edges that may be exposed to view.

Measuring the tile

Measure the distance from the edge of the grid flange to the upper flange of the shadowline trim and add 3mm. Mark this dimension on the face of the tile, measuring from one of the kerfed edges.

Cutting and installing the tile

Cut from the face side of the tile with a sharp cutter and a straight edge. Install this tile much as you would a full sized tile. Start with the cut edge going up and over the flange of the perimeter trim. Raise the tile up to the horizontal and then slide the kerfed edge back onto the grid flange.

Service Integration

The face of the Vector tile extends 13mm below the suspension system. The height of components that interface with the ceiling panels, such as sprinklers and light fixtures should be detailed accordingly.

Holes cut for sprinkler heads and other services must be cut slightly oversized to allow the tile to move in the direction of the 'A' edge. Collar trims for these devices must be wide enough to accommodate this 6mm movement.

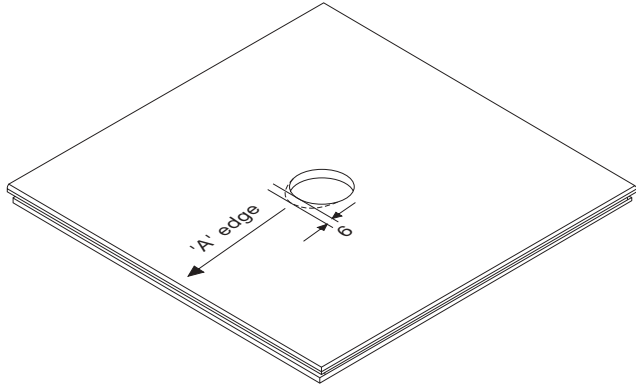

Vector fixture trim

These sections are used to create a flush ceiling appearance when standard lay-in service fittings are used.

Fixture trims (BP 5790 M④) are provided in pre-mitred lengths of plastic section. These clip onto the exposed flanges of the grid at the location of lay-in light fixtures or other accessories that sit into the grid in place of a ceiling tile. Trim elements may be installed before or after the placement of the ceiling tiles.

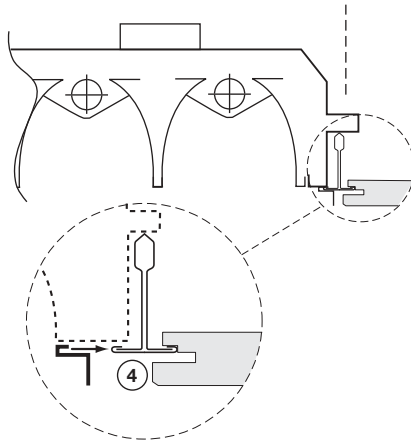

All measurements are in millimetres.

Vector light fitting

This fitting has been designed to integrate with the Vector ceiling system. The light fitting can be removed (and installed) from below.

Remove adjacent tiles and, using a screwdriver, loosen screw and retract holding bar (on both sides of the fitting) enough to allow the light fitting (ref. YRVEC) to drop below the grid and slide out. Full technical details available from Armstrong Internal Technical Sales Group.

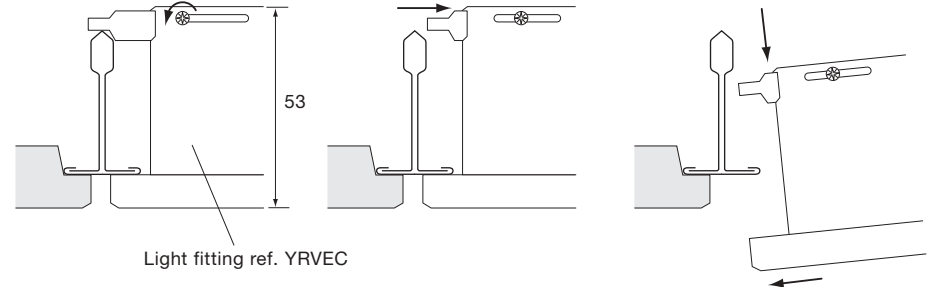

Vector air diffuser

A variety of air diffuser designs are available which integrate with the Ultima Vector ceiling system. Please contact Armstrong Internal Technical Sales Group for further details.

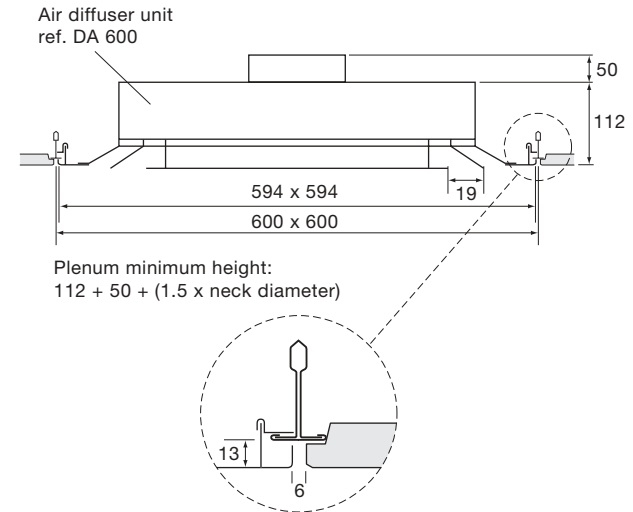

Cut corner tile

*Vector border clip BP A440 ②

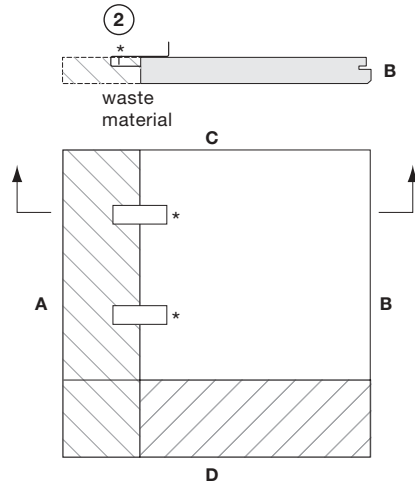

Spacer bar

Spacer bars ③ are recommended at the perimeters of all installations to help maintain proper tile alignment.

Border wedge

Where tiles are resting on the trim border wedges ① are necessary at cut perimeters to centralise tiles against registration kerfs.

Ultima Vector perimeter detail (full tile)

Full tile Ultima Vector installation with Axiom Transitions (BPT3210WR) and flush plasterboard surround.

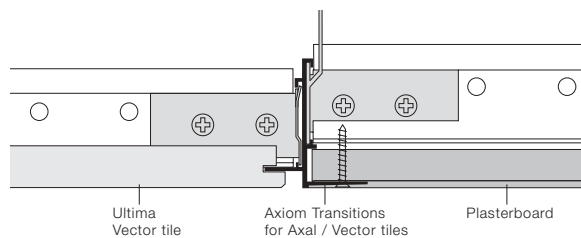

Installation and Removal

Ultima Vector ceiling tiles are easily installed and removed from below the suspension system without the aid of tools or special equipment, allowing easy downward access to the plenum.

Installation

Step 1

Place the deepest part of the edge **A**, the access kerf, into the grid flange.

Step 2

Raise the opposite edge **B**, the registration edge, into the grid opening.

Step 3

Slide the tile back into the grid flange, making sure the access edge **A** drops into position.

Removal

Step 1

Identify the access edge **A** by slightly pushing the tile in the centre, edge **A** is on the side which lifts the most. Raise the access edge **A** and slide the tile along, engaging the grid into the double kerf.

Step 2

Lower the registration edge **B** out of the grid.

Step 3

Slide the tile downward and release the access edge **A** from the grid.

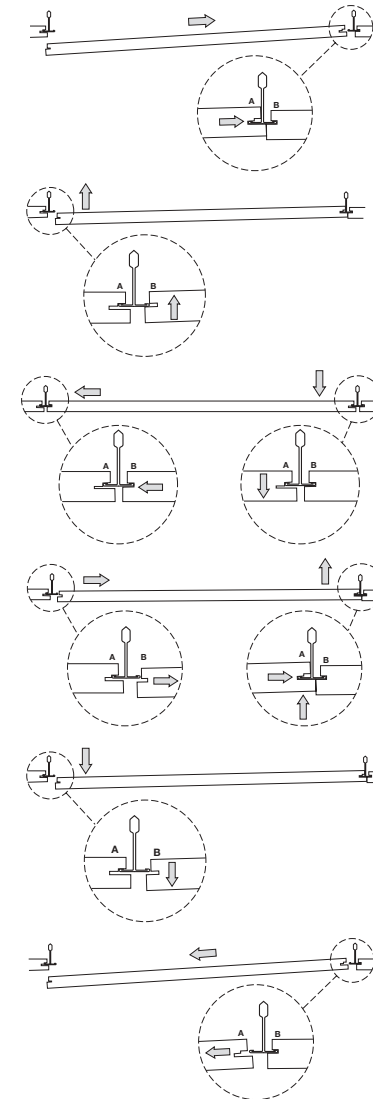

Acoustic Performance	Sound absorption (α_w) 0.70(H) Sound attenuation (Dncw) 36 dB
Tile Loading	Spotlights, luminaires and other service fittings should not be supported directly onto the back of the tile as damage or excessive deflection could occur. A pattress or other suitable method must be used to ensure that the fitting's load is transferred onto the grid, provided that the overall load does not exceed Armstrong's guidelines. Alternatively, direct independent suspension should be employed.
Service Integration	The design of the edge details used on Ultima Vector creates a gap between the face of the grid and the edge of the tile. This gap is necessary to allow the tile to lift sufficiently to permit installation and removal. This gap may be visually unacceptable when flangeless lighting fixtures are used. For this reason, fixture trim kits are available for use with Ultima Vector tiles (see Vector Fixture Trim).
Seismic Hold Down Clip	Ultima Vector seismic hold down clips are available for use on installations in areas of seismic activity. Please contact Armstrong Internal Technical Sales Group for further information.
Handling and Storage	Site storage and handling to the place of installation is generally provided by the Building Contractor. Armstrong pack their products so they will withstand careful site handling. Shrink-wrapping is not waterproof. Cartons may be handled numerous times from manufacture to installation, any rough handling, rolling or dropping cartons on their edges may cause damage to the product.

Please contact Armstrong Internal Technical Sales Group for further details.

United Kingdom
Republic of Ireland
Armstrong World Industries Ltd.
Building Products Division
Armstrong House
38 Market Square
Uxbridge UB8 1NG
0800 371849 (UK) 
1800 409002 (ROI)
Fax: 00 44 (0) 1895 274287
www.armstrong-ceilings.co.uk
e-mail: sales-support@armstrong.com
5 The Village Centre
Lucan
Co Dublin

<http://ceilings-eu.armstrong.com>

Thermal Conductivity	0.052-0057 (λ) W/m ² K
Humidity Exposure	95%RH
Fire Reaction	Class 0 (UK & ROI Building Regulations) Class 1 (BS 476: Part 7)
Weight	5.2 kg/m ²
Field Cutting	Cut from the face side of the tile with a sharp knife. Cut tile edges that are exposed to view will have to be treated to look like factory painted edges. Armstrong ceiling tile Touch-up Paint (item nr. BP AFP) is recommended.
Cleaning	Should the need arise to redecorate Armstrong Suspended Ceilings, contact should be made with our Internal Technical Sales Group who will provide advice regarding general cleaning and painting precautions.

All product specifications are subject to modifications without prior notice.

